

SOLANA

COLLECTION

PAVILION

HAVANA

Free standing double sided awning structure.

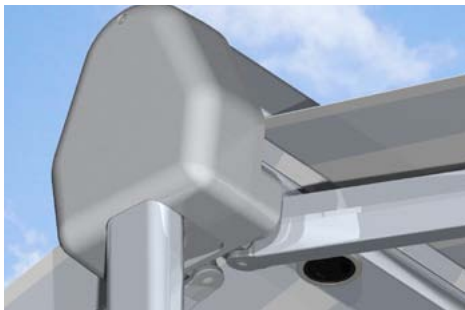

FEATURE & BENEFIT

- A double sided free standing retractable awning
- No centre posts provides optimal space for dining, seating or pool area
- Self supporting box construction retracts in own housing protecting fabric
- Motor and Wireless remote control with Wind Sensor option
- 10 year warranty

FABRIC & COLOR

- European Mill production
- 100% solution dyed acrylic
- High UV and soil resistance
- Ultra color fast doesn't fade
- Excellent water repellency

HEAVY DUTY GUIDING

- European aluminum profile

Width 10' up to 18'

Projection 10' up to 14'9"

SATTLER
thinking highTEX



Request a
complimentary
consultation

905-337-7707

DeckStore.ca/SolanaCollection

PLANTATION

Free standing double sided awning structure.

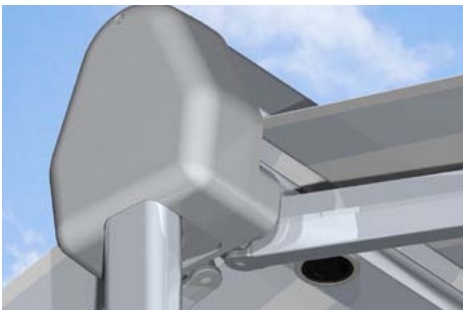

FEATURE & BENEFIT

- Independently operated double sided free standing box awning
- Tensioned system remains taut in any position excellent under windy condition
- Mounting options ground sleeve or concrete foot
- Motor and Wireless remote control with Wind Sensor option
- 10 year warranty

FABRIC & COLOR

- European Mill production
- 100% solution dyed acrylic
- High UV and soil resistance
- Ultra color fast doesn't fade
- Excellent water repellency

HEAVY DUTY GUIDING

- European aluminum profile

Width 8'7" up to 20'

Projection 10' up to 23'

SATTLER
thinking highTEX



Request a complimentary consultation

905-337-7707

DeckStore.ca/SolanaCollection